

- 180°, 60% nest for a stable stack during summer months
- Can be stacked up to 5 high
- Forklift and picker truck lifting slots for added manoeuvrability
- Generous capacity:
 - Small 7cuft (200L)
 - Large 14cuft (400L)
- Moulded in Grit salt sign
- Personalization label recess
- Durable pultruded rod hinge
- Gold banding option available



LINPAC Grit Salt Bins

A high performance plastic moulded grit salt bin, combining modern styling, a generous capacity and functionality in equal measure



- 31** Golden yellow
- 48** Sandstone mottle
- 67** Signal red
- 74** Dark green
- 169** Slate grey mottle
- 02** Black

Other colours available on request subject to minimum order quantities



- Double skin perimeter lid for improved rigidity
- Double skin lip and rim structure to improve load bearing properties
- Robust rib structure for added strength and wear resistance in base
- Hasp & staple lock option

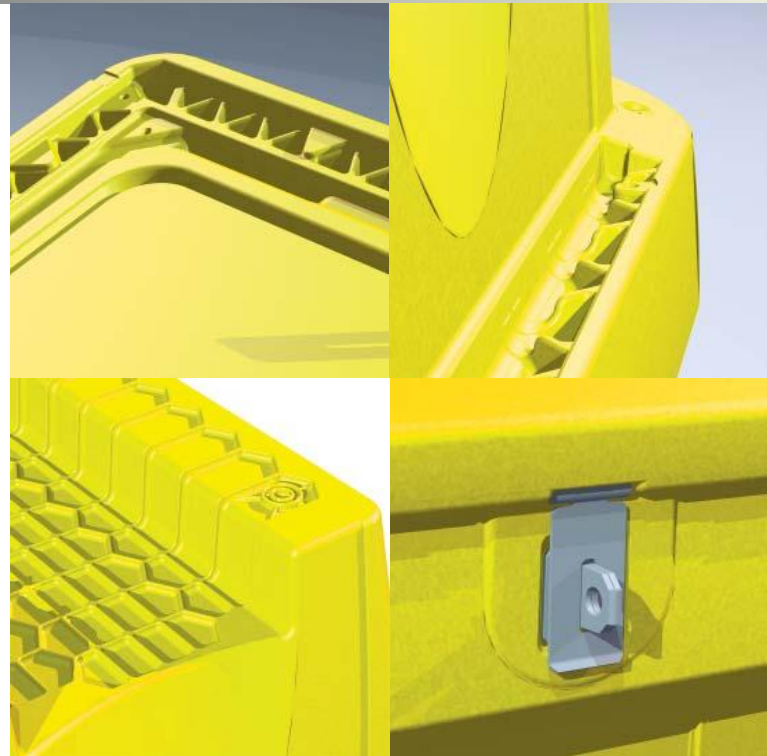

Dimensions				
	a	b	c	d
Large	775	805	540	1380
Small	540	625	450	1110
All dimensions in millimetres				

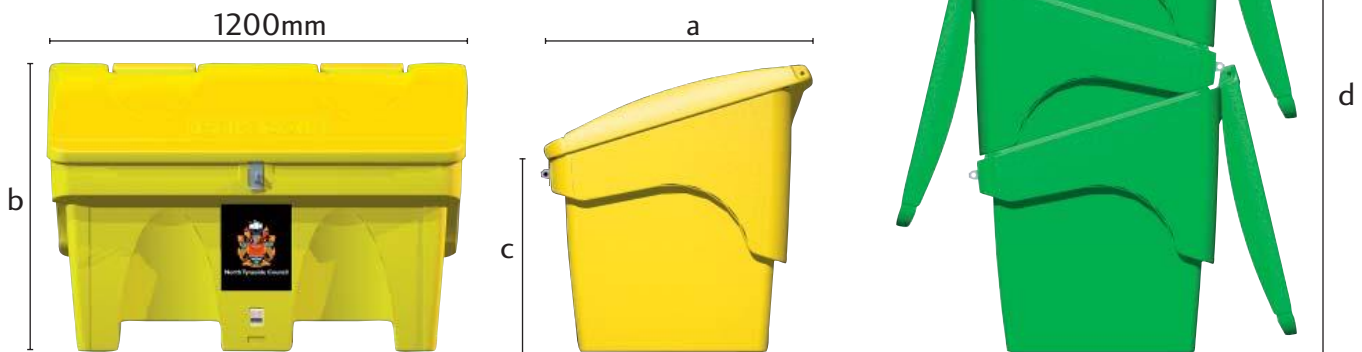

Durability Moulded polyethylene (PE) is extremely durable with outstanding impact, fracture and shatter resistance properties. These mechanical properties are tested to BS 2782



Chemical Resistance The material is resistant to most acids, salts and solvents. Environmental elements such as acid rain, soot, diesel fumes, salt and seawater will not corrode PE



Weather Stability PE is ideal for external applications. Materials used are UV stabilised to meet the demands of Northern Hemisphere weather conditions.



Maintenance Free The solid body colour is permanently moulded-in, eliminating the need for maintenance painting. Units are wear resistant, scratches and parking nudges are less evident.

Merlin

Industrial Products Ltd

Kingsley Close, East Way
Lee Mill Industrial Estate
Ivybridge, DEVON PL21 9LL
United Kingdom
Call 0845 124 9955
Fax 0845 125 9955

sales@mipl.org.uk