



## MAIN FEATURES

Excellent hydraulic stainless steel pump unit for low maintenance

Heavy duty stainless steel construction

All parts are stainless steel

Three position trigger  
Lifting-neutral-Lift

Nylon double fork rollers and wheels fitted as standard.

Entry/exit rollers on the forks for easy pallet entry/exit.

Specially designed for use in the food industry and will lift most pallet sizes in use.

TUV/GS approved and CE Rated.

Other fork sizes are available for this model from 1100mm to 1220mm long and 540mm to 685 wide

Spare parts available  
From stock

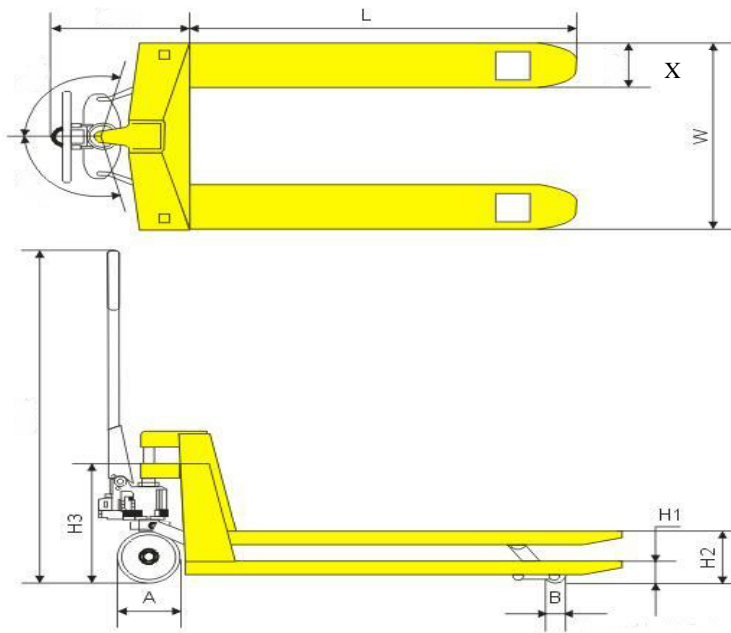

MODEL	ACS25		
Capacity		kg	2000
Min fork height	H1	mm	85
Max fork height	H2	mm	200
Steering wheel size	A	mm	200x50
Fork roller size	B	mm	80x70
Fork width	X	mm	160
Fork length	L	mm	1150
Width	W	mm	540
Steering		°	205°



**Merlin**  
Industrial Products Ltd

0845 124 9955 Telephone  
0845 125 9955 Fax  
sales@mipl.org.uk E-mail  
www.merlin-industrial.co.uk Website  
Address  
Lee Mill Industrial Estate  
Ivybridge, DEVON  
United Kingdom Company Number 2906480