



Eoslift

DBA25-A PALLET TRUCK



Excellent 2500kg capacity low maintenance hydraulic pump unit.

Heavy duty steel construction with epoxy powder coated finish to give greater ant-corrosion resistance.

Three position release trigger with Neutral, Lift and Lower settings.

Polyurethane double fork rollers and wheels fitted as standard.

Rollers are fitted on the forks for easy pallet entry/exit.

Industry standard design that will lift and move most pallet sizes in use.

TUV/GS approved and CE Rated.

Other fork sizes are available in the range, please see other models on our site for details.

Polyurethane are generally the most popular wheel type and are a cast wheel with a polyurethane tyre around the outer, this wheel gives a better grip on smooth floors and is quieter running than Nylon.

This softer wheel type also tends to be better for use on delicate flooring (finished floor surface).

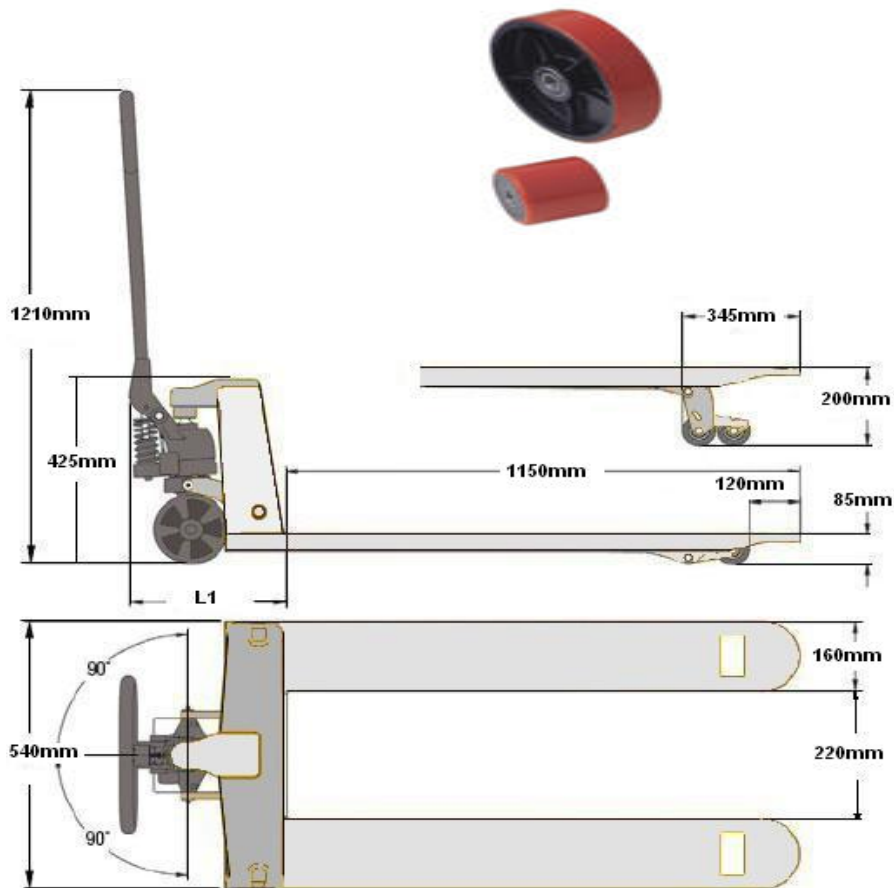

**Pallet Truck
Check**



Also consider buying our
Pallet Truck Check



**1 year warranty on
pump unit**



**Certificate of
Conformity available
on request**



**UK mainland orders
delivered in 1-2
working days**

Merlin

Industrial Products Ltd

0845 124 9955 Telephone
0845 125 9955 Fax
sales@mipl.org.uk E-mail
www.merlin-industrial.co.uk Website
Address
Lee Mill Industrial Estate
Ivybridge, DEVON
United Kingdom Company Number 2906480